



KREMEN
URBAN FURNITURE

YEARS

OVER
30



URBAN FURNITURE CATALOGUE

Your local authorized reseller:



reddot winner 2024
urban design

Bien family

DESIGNED BY
JUDAR DESIGN



reddot winner 2024
urban design

Soft lines, timeless design, and durable materials — this is Bien. It is urban furniture designed to meet the needs of modern public space users. The line includes a wide range of products that function as individual elements or as a cohesive whole. Bien does not merely conform to basic functions it also enriches the spatial experience and fosters a dialogue with the surroundings. In doing so, the line sets new standards in urban design, where aesthetics, functionality, and social aspects work in perfect harmony. The litter bin recently received the prestigious Red Dot Design Award, highlighting the harmonious relationship between design solutions and the materials used.

AVAILABLE MATERIALS



WHITE



BEIGE



BLACK



TROPICAL WOOD



GROUND ANCHORING POSSIBLE



POWDER COATED



ZINC PLATED



STAINLESS FASTENERS



3D MODEL ON WEBSITE

Bench Bien

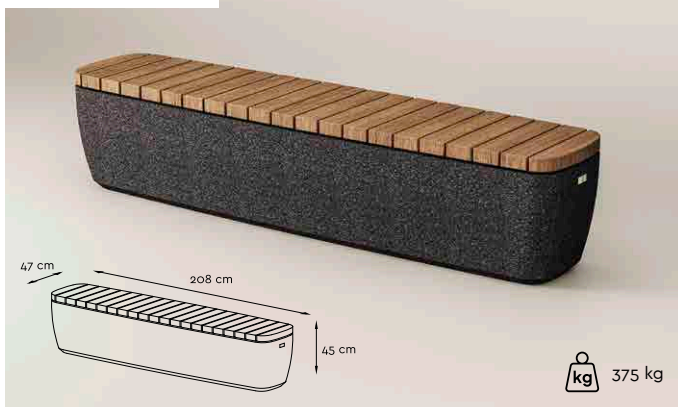

Bench Bien with a backrest

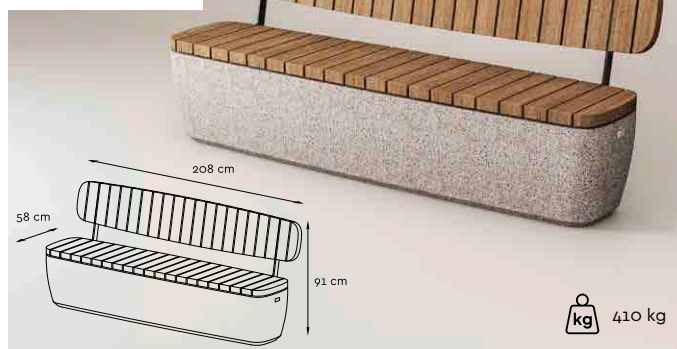

Solar bench Bien

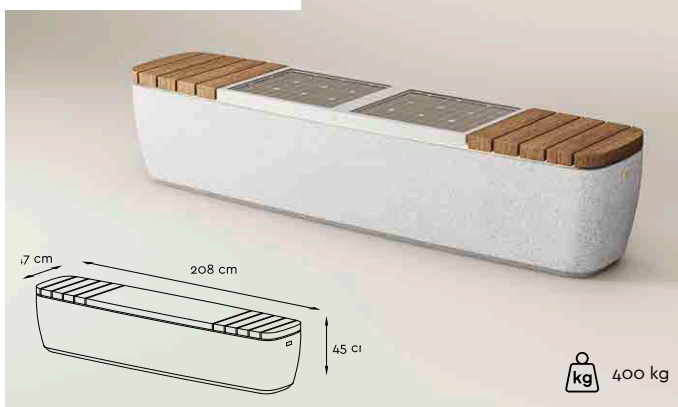
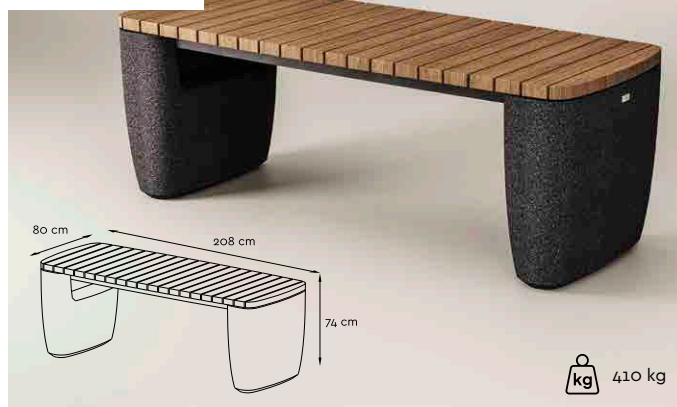
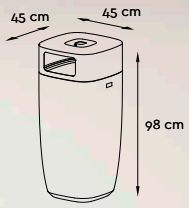

Table Bien



Bin Bien



kg 125 kg

Recycling bin Bien

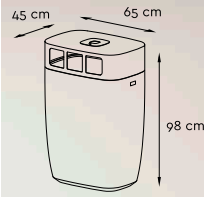

kg 160 kg

Planter Bien S1

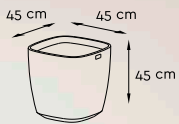

kg 62 kg

Planter Bien S2

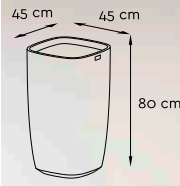

kg 110 kg

Planter Bien S3

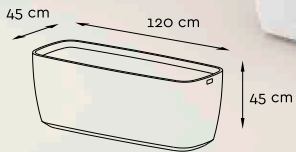

kg 160 kg

Planter Bien S4

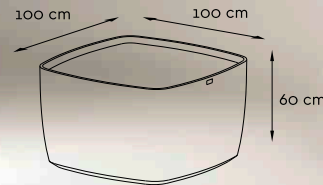

kg 280 kg

Drinking fountain Bien

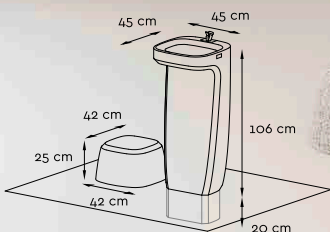

kg 246 kg

Barrier Bien

kg 67 kg



kg height 83 cm (installed)
width 20 cm
length 20 cm

Bike stand Bien

kg 80 kg



kg height 84 cm (installed)
width 20 cm
length 83 cm



Pebble family

The Pebble Urban Furniture Collection brings together nature-inspired design and urban functionality. Featuring benches, waste bins, bicycle stands, and planters, this collection is designed to create inviting and durable public spaces while maintaining a distinct organic aesthetic. Each piece is crafted from natural river pebble stones, offering a unique texture and exceptional durability. The fusion of raw, natural materials with sleek metal and wood elements results in a balanced design that integrates seamlessly into parks, plazas, waterfronts, and residential areas. Built for resilience and low maintenance, the collection withstands harsh weather, urban wear, and vandalism, ensuring long-lasting performance. The Pebble Collection transforms outdoor environments by adding warmth, authenticity, and a connection to nature while meeting the demands of contemporary public spaces.

AVAILABLE MATERIALS



GREY RIVER GRAVEL



TROPICAL WOOD



LARCH



SPRUCE



GROUND ANCHORING POSSIBLE



POWDER COATED



ZINC PLATED



STAINLESS FASTENERS



3D MODEL ON WEBSITE

Barrier Chuck



diameter 40 cm
height 40 cm

110 kg

Bin Berni

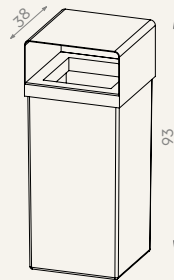

120 kg

Planter Urbano 50



diameter 50 cm
height 48 cm

60 kg

Planter Urbano 75



diameter 75 cm
height 65 cm

285 kg

Bench Quadro 420



Table Quadro



Bin Lixo 50L



Bin Lixo 75L



Planter Linia

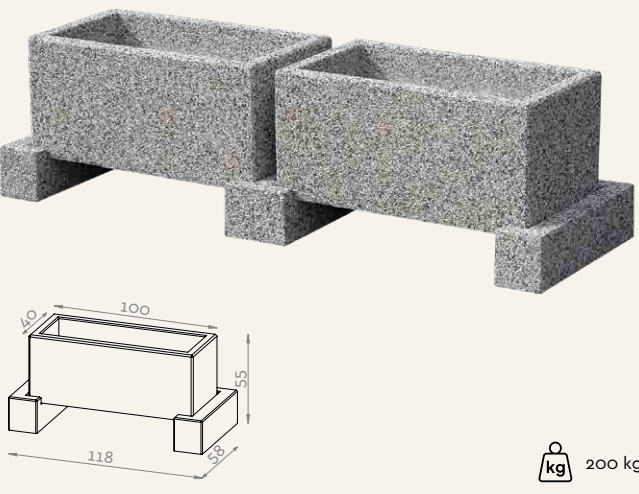

Stand Groningen

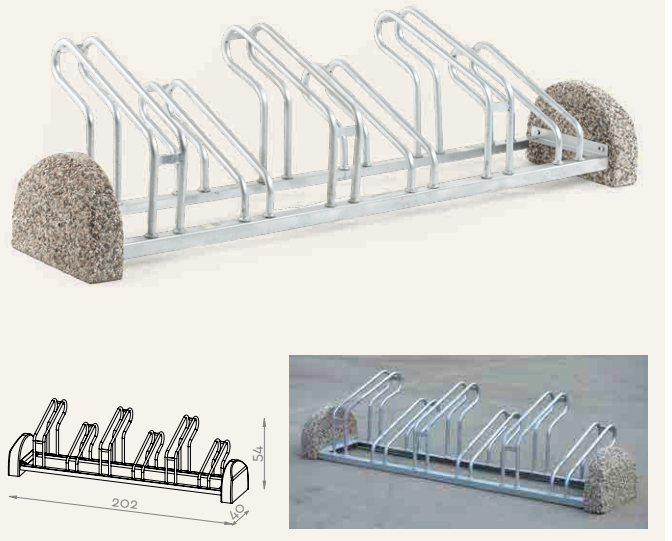

Greyline Family



The GreyLine collection is a thoughtfully designed set of outdoor elements that combine functionality, durability, and modern aesthetics. Featuring benches, waste bins, bicycle stands, and planters, this family provides a cohesive solution for contemporary urban landscapes. Each piece is crafted from high-quality, weather-resistant materials, including galvanized powder-coated steel ensuring longevity and resilience against the elements. The collection's clean, minimalist design allows it to integrate seamlessly into diverse environments, from historic city centers to modern commercial and residential spaces. With a focus on ergonomics, sustainability, and low maintenance, GreyLine enhances public spaces by promoting comfort, cleanliness, and greenery. Designed for parks, plazas, business districts, and pedestrian zones, it brings harmony and functionality to urban settings while maintaining a sophisticated visual identity.

AVAILABLE MATERIALS



GREY RIVER GRAVEL



WHITE



BLACK



TROPICAL WOOD



LARCH



SPRUCE



GROUND ANCHORING POSSIBLE



POWDER COATED



ZINC PLATED



STAINLESS FASTENERS



3D MODEL ON WEBSITE

Bin Park with lid

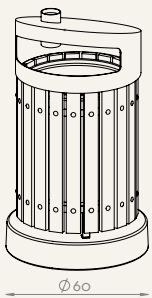

106

Ø 60



kg 100 kg

Bin Park

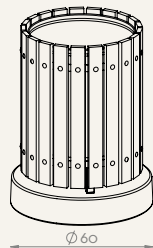

78

Ø 60



kg 90 kg

Bench Madrid

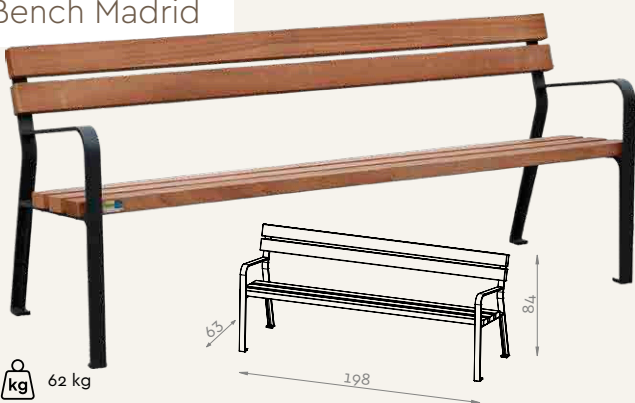

63

84

198

kg 62 kg

Stand Uno Basic

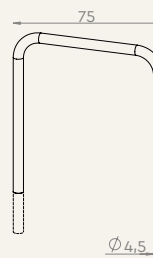

75

90

Ø 4,5



kg 3 kg

Stand Riam



kg 6 kg

Barrier Aero



height 95 cm (installed),
section 7x7 cm

kg 10 kg

Planter Orland



kg 200 kg

Planter Otis



kg 168 kg

Planter Oswald

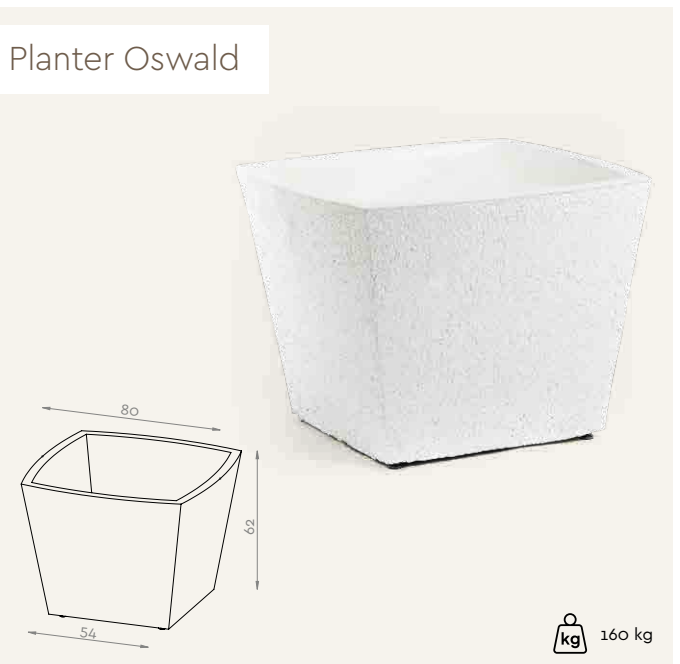

kg 160 kg

WASHED CONCRETE

In quarries massive stone blocks are crushed and river gravel is sifted into sand fractions, which we incorporate into our concrete elements. We use natural stone, allowing its authentic color and texture to shine in the final product. Elements are molded using high-frequency vibration technology, ensuring uniform distribution, combined with washed concrete technique. The result is a high-quality, weather-resistant material, impervious to aging and frost-induced flaking. Our concrete achieves a compressive strength exceeding 60 MPa and can be easily cleaned with high-pressure washers. All concrete surfaces are treated with a water-repellent protective coating, preventing dirt accumulation and moss growth.

WHITE



BEIGE



BLACK



GREY RIVER GRAVEL



WOOD SELECTION

We work exclusively with durable, high-quality wood, each type carefully selected for its strength and longevity.

Wood is a gift of nature, making each piece unique. Natural variations in color, grain, and texture are inherent, contributing to its authentic appeal. Over time, exposure to the elements develops a silver-grey patina. To preserve its original color and extend its lifespan, we recommend periodic treatment with protective oil.

TROPICAL WOOD



- Deep reddish-brown hue, varying with species and tree age.
- Naturally durable, even without maintenance.
- Density: over 670 kg/m³.
- Durability class: 2. (EN 350) – highly resistant to biological agents.

LARCH



- Slow growth results in denser growth rings.
- Characterized by natural knots, adding unique character.
- Pre-treated with special oil for enhanced durability.
- Density: 600 kg/m³.
- Durability class: 3-4 (EN 350).

SPRUCE



- A clean, fine-grained wood with minimal resin pockets.
- Pre-treated with protective oil to extend lifespan.
- Sourced from Slovenia.
- Density: 460 kg/m³.
- Durability class: 4 (EN 350).

ABOUT US

For more than three decades, we have been crafting **urban furniture, and concrete design elements**, establishing ourselves as one of Slovenia's leading companies in this field.

In recognition of our commitment to excellence, we have received several prestigious awards:

- **2006** – "Srebrni Ceh" award
- **2019** – AAA Credit Excellence Certificate
- **2024** – **Red Dot Design Award** for the Bien waste bin

We continuously innovate in design and technical solutions to offer contemporary, high-quality products that enhance architectural and public spaces.



- 📍 Kremen MB, d.o.o.
Ulica heroja Šaranoviča 34C, 2000 Maribor, Slovenia
- ☎ +386 2 252 46 87
- ✉ info@kremen-mb.si
- 🌐 www.kremenurban.com